

IDEAL

▶ ENGINEERING DATA:

IDEAL STITCHER
DIVISION

Ideal Stitcher Company
Division of W.R. Pabich
2323 N. Knox Avenue
Chicago, IL 60639

Phone: 773-486-4141 Fax: 773-486-4812
Email: wrpabich@sbcglobal.net
Website: www.idealstitcherco.com

WIRE STITCHERS

Stitches Regular
Slotted Containers
and Full Overlap Cartons

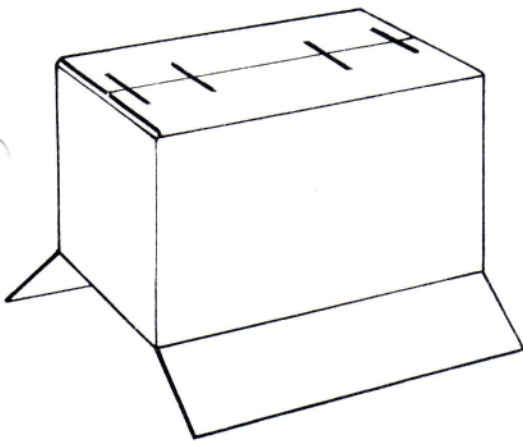

FEWER STAPLES

MORE STRENGTH

1 3/8 inch wide crown staple
POST STITCHER FOR CARTON BOTTOMS

25 pound coil uses
.037 x .074 wire; produces
14,250 staples.

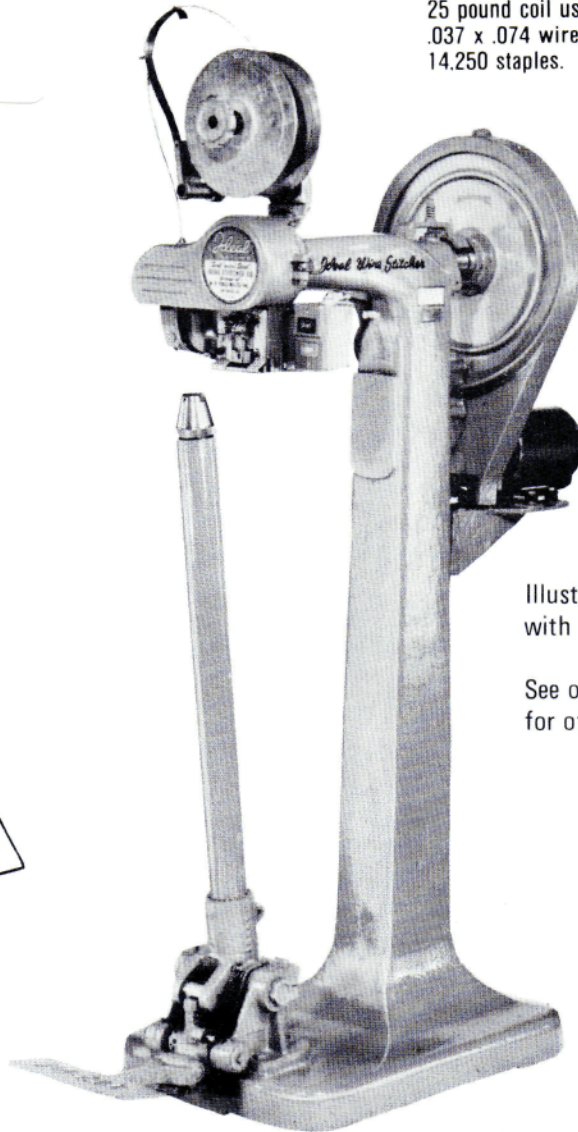

Illustrated: WSIB-1240
with 12 inch throat

See other side
for other sizes

pedal folds
back when
not in use

CUT

FORM AND CLINCH

STAPLES, INSTANTLY!



YOUR IDEAL REPRESENTATIVE:

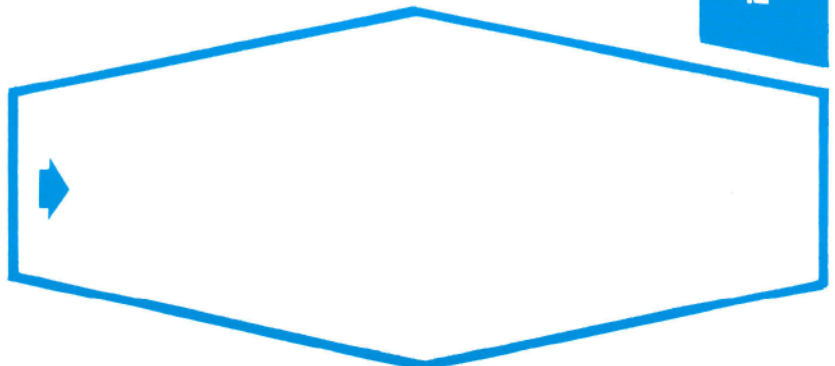

**1³/₈ inch wide crown staple
POST STITCHER FOR CARTON BOTTOMS**

MACHINE MODEL	CROWN SIZE	WIRE	COIL	STAPLES PER COIL (Approx.)	THROAT	USABLE POST HEIGHT	CRATED WEIGHT (LBS.)
WSIB-1240	1-3/8"	.037 x .074	25 Pounds	14250	12"	40"	470
WSIB-2043	"	"	"	"	20"	43"	620
WSIB-2540	"	"	"	"	25"	40"	660
WSIB-3040	"	"	"	"	30"	40"	740

SPECIFICATIONS: All equipped with 25 pound coil; 1/3 hp 115V 60 cycle 1 ph motor; push-button start-stop switch.

Machines are also made in standard 7/16th inch crown, or 1¼ inch crown models, as well as in various other crown and wire sizes.

Special machine heights can be made to order.

Variable speeds also available.

Ideal Stitcher Company
Division of W.R. Pabich
 2323 N. Knox Avenue
 Chicago, IL 60639
 Phone: 773-486-4141 Fax: 773-486-4812
 Email: wrpabich@sbcglobal.net
 Website: www.idealstitcherco.com